

SMARTFLOW®

FasTie® Quick-Connect Knock-Out System

2-Inch Components, Installation Instructions

US Patent No. 6,379,072



General

FASTIE Quick-Connect Knock-Out System “ties-in” the mold ejector plate to the press ejection system. A pneumatically-operated piston inside the coupler releases the stud from the press ejection system to reduce set-up and change-out times.

Fixed-length *FASTIE* ejector bars may be used with the couplers and studs. The *FASTIE* air manifold option distributes shop air to each coupler. The aluminum manifold supplies up to four couplers. Pneumatic fittings and tubing are included.

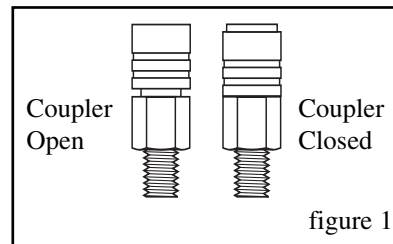

Caution: *Female couplers must be in the open position before connecting with the male studs. See figure 1. Coupler damage will result from improper set-up.*

Maintenance

FasTie couplers must be greased to operate smoothly. Visually inspect coupler each month or each tool change for the presence of grease. Generously apply grease to stud end, connect the coupler to the stud, then release and repeat.

Before Installation

Before clamping a mold to the injection molding machine, the machine ejector plate must be completely retracted to the “home” position.

burger & brown engineering, inc.

4500 E. 142nd Street • Grandview, MO 64030 • Tel. (816) 878-6675 • Fax (816) 878-6683 • www.smartflow-usa.com

Fixed Bar Installation

The following installation instructions are for reference only. Installation may vary depending on knock-out arrangement and pneumatic connection location.

1. Install studs into the mold ejector plate. See figure 2. Shoulder should be flush with the back face of the mold clamp plate. If the press has a non-adjustable ejector home position, it may be necessary to insert washers under the stud. Use a thread-locking compound where threaded parts connect to prevent movement during use.
2. Insert the knock-out bar and coupler through the platen and into the press ejector plate. For presses with non-adjustable ejector home position, install the coupler (in the open position) flush with the platen surface. The outer sleeve of the coupler will be flush with the platen surface only in the open position. See figure 3.
3. Clamp A side mold plate to the machine. The mold must be positioned squarely inside the press.
4. Install washer, nut and pneumatic connector per figure 4. Use a thread-locking compound to prevent movement during use.
5. If using the manifold accessory, mount the manifold and tubing so they do not interfere with moving parts.
6. Connect shop air lines to the **FAS^TIE** couplers. **Couplers must be in the open position (see figure 1) before connection to studs, otherwise coupler damage will occur.**
7. Move the platen forward so the coupler and stud are connected.
8. Clamp the B side of the mold to the platen. Tighten the nut to the press ejector plate after FasTie components are coupled. This assures alignment of the FasTie system.
9. Follow “Test Installation” procedure below.

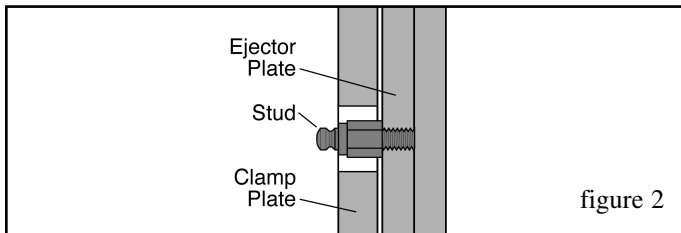

figure 2

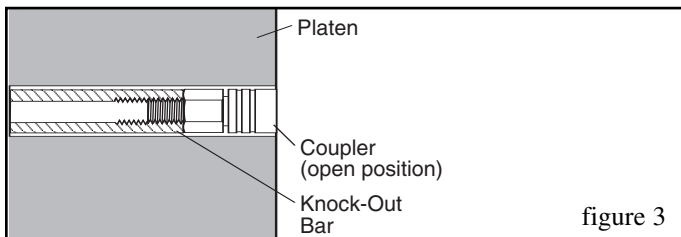

figure 3

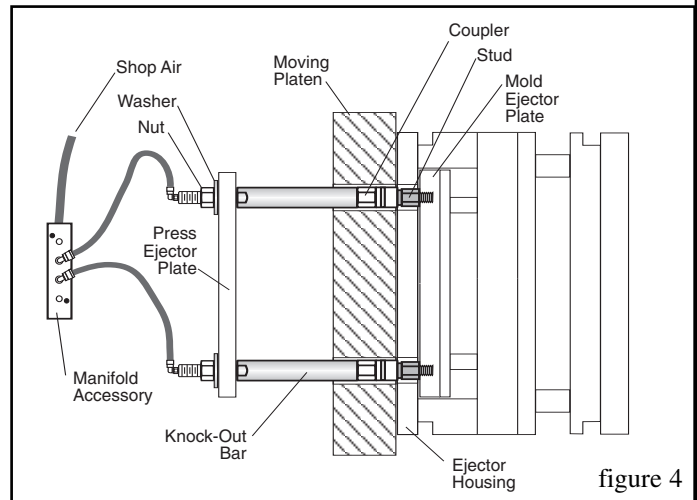

figure 4

Test Installation

Verify Connection

1. Open the mold.
2. Activate the ejector system.
3. Observe the ejector pins. They should move forward and return. Visually inspect the FasTie couplers to verify that they are connected to the studs.

Verify Release

1. Apply air to the **FAS^TIE** couplers.
2. Activate the ejector system.
3. Observe the ejector pins. They should move forward, but not return.

Reconnect Couplers

1. Ensure that the **FAS^TIE** couplers are in the open position and the air pressure is off. See figure 1.
2. Move the ejector system forward
3. Return the ejector system.
4. Observe the ejector pins. They should be retracted

If the system is not connected properly, open the platen, disconnect the couplers and studs, and reconnect each knock-out bar (repeat Steps 7 through the end of installation, and re-test the installation).

Troubleshooting

Symptom	Corrective Action
Ejector pins don't move back when retracting ejector system; FasTie does not connect	<ul style="list-style-type: none">• Check air pressure to the coupler (should be between 80 and 100 psi) testing air lines for leaks or breaks.• Check coupler operation.• Check stud and coupler alignment.• Pneumatic valve or selector switch must allow residual air pressure to dissipate when valve is "off". Air pressure when "off" is zero.
FasTie uncouples during ejector cycle	<ul style="list-style-type: none">• Check mold position in the machine. Mold must be squarely installed and the FasTie coupler must not contact the platen.
FasTie doesn't uncouple	<ul style="list-style-type: none">• Check length of fixed or adjustable knock-out bars.• Check that the mold is clamped squarely to the machine.• Check air pressure (should be between 80 and 100 psi) testing air lines for leaks or breaks.• Apply grease to coupler per "Maintenance" on Page 1.

If corrective action fails to correct the problem, please contact the factory.

Limited Warranty

Seller warrants that this product supplied will conform to the description herein stated and that the product will be of standard quality. This is the sole warranty made by Seller with respect to this product. Seller expressly disclaims any other express or implied warranties, including, but not limited to, the implied warranty of merchantability and the implied warranty of fitness for a particular purpose.

Seller shall not be liable for any cost or damages, whether direct, incidental or consequential, including, but not limited to, any injury, loss or damage resulting from the use of this product, regardless of whether any claim for such cost or damages is based on warranty, contract, negligence, tort or strict liability. The sole liability of Seller is limited to repairing or replacing this product.

This warranty shall not apply to any products that have been repaired or altered by anyone other than Seller. The warranty shall not apply to any products subject to misuse due to common negligence or accident, nor to any products manufactured by Seller which are not installed or operated in accordance with the printed instructions of Seller or which have been operated beyond the rated capacity of the goods. Seller states that the product's useful safe life is 5 years. Actual life may vary widely depending on operating environment such as temperature, pressure, and chemical exposure.