



High Temperature Low Flow Indicator

Installation and Operating Instructions

Applies to: HTLFI3-A-40, HTLFI3B-A-40

General

Smartflow High Temperature Flow Indicators are designed to show the presence of flow in very low flow applications. This high temperature indicator comprises high-visibility impeller and robust flow body designed for punishing duty.

High Temperature Low Flow Indicators are ideal for use in critical injection mold cooling circuits such as bubblers or baffles where flow is restricted and effective cooling is essential.

We recommend using only extremely clean cooling water through the attached channels to reduce the buildup of deposits in high temperature applications. Scale deposits can coat the insides of cooling water channels effectively creating barrier insulation in water lines, preventing efficient heat transfer.

Flow indicator operates equally in both directions.

Specifications

Flow Range	0.3 - 4 LPM (0.08 - 1 GPM)
Connection size	3/8"NPT or BSPP
Max. Temperature	204°C (400°F)
Max. Pressure.....	17.2bar (250psi)

Component Materials

Flow Body.....	Stainless Steel
Rotor	Nylon
Shaft	Stainless Steel
Viewing Window	High-Temperature Glass
O-Ring.....	PTFE

Installation Best Practices

The flow indicator is line-mounted without additional support.

1. For best results, install the flow indicator with 4" of straight pipe before the inlet of the flow indicator, and 2" of straight pipe after the outlet of the flow indicator.
2. Use a pipe thread sealant compatible with the maximum operating temperature and process fluid (Loctite #567 or equivalent).
3. Cooling media should be extremely clean. High temperature cooling media should be filtered at a minimum. Water treated using reverse osmosis is preferred. Any impurities in the water are likely to cause scale buildup in cooling lines and deposits causing malfunction of the low flow indicator.



Warning!

High temperature cooling applications pose a serious personal injury hazard. Use extreme caution, protective clothing, or shielding around the system to minimize risk to personnel and nearby equipment.

Any liquid system offers the potential for accidental leakage. Leakage onto electrical or computer equipment could result in costly damage or personal injury. Do not locate piping systems where leakage might damage equipment or pose personal injury hazards. If it is impossible to avoid piping in such locations, use shielding to protect equipment and personnel.



4500 E 142nd Street • Grandview, MO 64030
Tel. (816) 878-6675 • www.smartflow-usa.com

Maintenance

Occasional cleaning of the internal parts is recommended for optimum operation.

1. Remove the four cover plate screws. Remove the window and rotor.
2. Thoroughly clean flow path and the window glass.
3. Always replace the o-ring whenever the glass window is disturbed.
4. Replace the cover taking care not to crack the window.
5. Place a small amount of high temp thread lock compound on the cover screw.
6. Thread screws in a cross pattern to tighten.
7. Continue tightening gradually to 85 in-lb torque each.

CAUTION

Screws may loosen with temperature cycling. Periodically tighten the cover screws to torque specification.

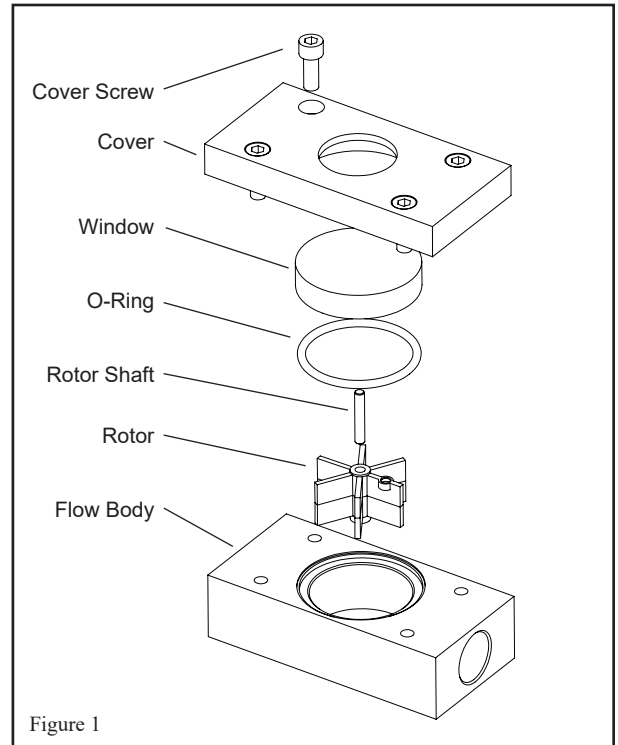

Figure 1

Replacement Parts List

Item	Factory Part Number
Cover Screw.....	SHCS-10X24-.5-SS
Window.....	HTLF-GL
O-Ring.....	568-126-0000-75
Rotor Shaft.....	HTLF-PIN
Rotor	EFR-770-TEF

Limited Warranty

Seller warrants that Smartflow® products supplied will conform to the description stated in published literature, and that the product will be of standard quality. The seller warrants manufactured components for 90 days. This is the sole warranty made by Seller with respect to this product. Seller expressly disclaims any other express or implied warranties, including, but not limited to, the implied warranty of merchantability and the implied warranty of fitness for a particular purpose.

Seller shall not be liable for any cost or damages, whether direct, incidental or consequential, including, but not limited to, any injury, loss or damage resulting from the use of this product, regardless of whether any claim for such cost or damages is based on warranty, contract, negligence, tort or strict liability. The sole liability of Seller is limited to repairing or replacing this product.

This warranty shall not apply to any products that have been repaired or altered by anyone other than Seller. The warranty shall not apply to any products subject to misuse due to common negligence or accident, nor to any products manufactured by Seller which are not installed or operated in accordance with the printed instructions of Seller or which have been operated beyond the rated capacity of the goods. Seller states that the product's useful safe life is 5 years. Actual life may vary widely depending on operating environment such as temperature, pressure, and chemical exposure.